

Manual Operation of Liposome Hand-Extruder

Catalog No. HandExtruder-1mL;
HandExtruder-1mL-RT



1. Open-box Inspection

Check whether there is any packing damage. Refer to the parts list for the integrity of the product.

2. Product Introduction

2.1 Introduction

The liposome and lipopolyplex are used for drug, protein and gene delivery. Liposome Hand-Extruder system is applicable for formulation design of liposome and lipopolyplex. The parts contacted with the medium are made of 316L stainless steel or material such as titanium alloy which is more resistant to strong acid and base. The protective film outside of the gas-tight syringe gives the extra-protection for syringe and user.

2.2 Specification

Maximum pressure	700 psi
Finished product size	50 nm-500 nm
Maximum concentration	200 mg/mL
Operation capacity	0.5 mL / 1.0 mL
Temperature control	Optional
Material standard	Pharmaceutical grade

3. Safety Notes

 **Warning:** The syringe is made of glass, please check if the syringe cylinder has any cracks before use; additionally, do not overexert yourself during operation.

 **Danger:** Always check the wear pattern of all O-rings, and replace them if necessary. During the operation, damaged or worn O-rings may rupture suddenly, which could lead to a sudden decompression of the extruder.

 **Warning:** Gently lift and move equipment to avoid personnel injury.

 **Warning:** Genizer™ Hand-Extruder should be performed in accordance with the relevant safety requirements. The operator must use protective clothing or shelter. The operator should be responsible for any personal or property damage caused by safety requirements violations.

 **Warning:** Using original parts to replace worn or damaged parts. Replacement with non-original parts will not be warranted.

4. Parts List

Genizer™ Liposome Hand-Extruder includes the following parts.

Part No.	Part name	Quantity
----------	-----------	----------

1	Container nut	2
---	---------------	---



For HandExtruder-1mL

2	Housing	1
---	---------	---

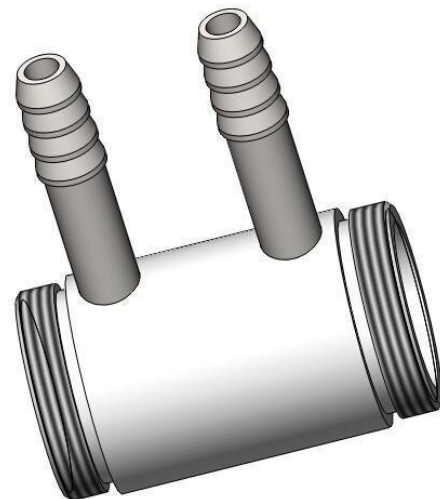

For HandExtruder-1mL-RT

Part No.	Part name	Quantity
----------	-----------	----------

3	O-ring support	1
---	----------------	---

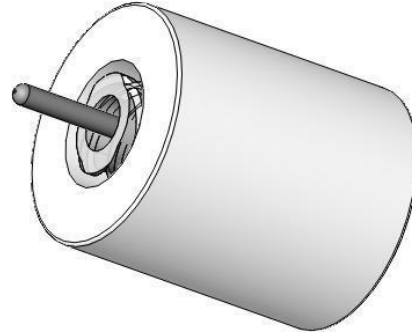

4	O-ring	2
---	--------	---

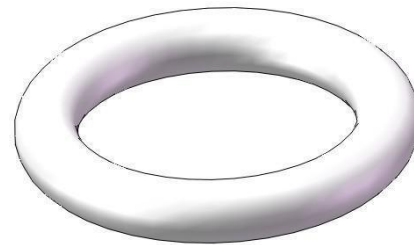

5	Stabilizer	1
---	------------	---

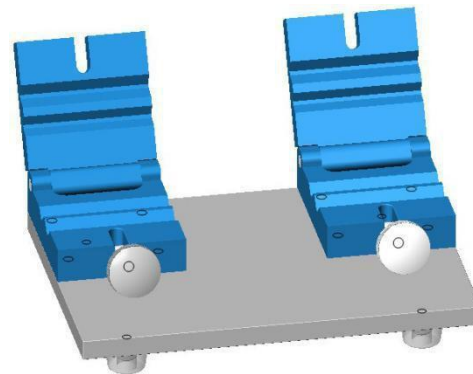

5. Assembly Procedure

The table below describes the assembly steps of Genizer™ liposome Hand-Extruder. Refer to the Parts List for assembly.

Step 1

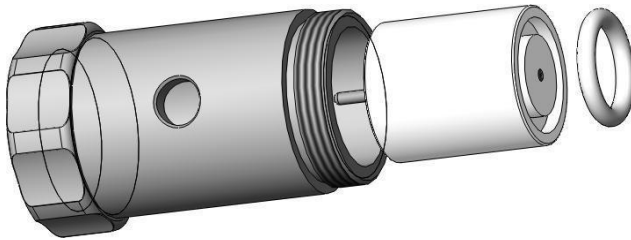

Connect the container nut (1) with the housing (2) through screwing on it.

Step 2



Install the O-ring (4) into the O-ring support (3), and then place it into the assembly in step 1.

Step 3



Carefully place the sintered disc, membrane, sintered dish on the assembly components of O-ring (4) and O-ring support (3) in step 2. Note: The Nanopore membrane must be flat and wet without any wrinkle or bubble.

Step 4

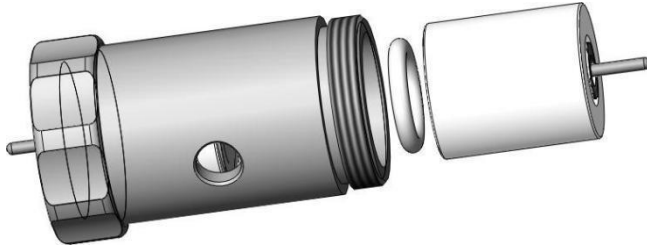

Like step 2, on the other side, install the second O-ring (4) into the second O-ring support (3), and then place it into the components assembled in step 3; pay attention to the installation direction.

Step 5

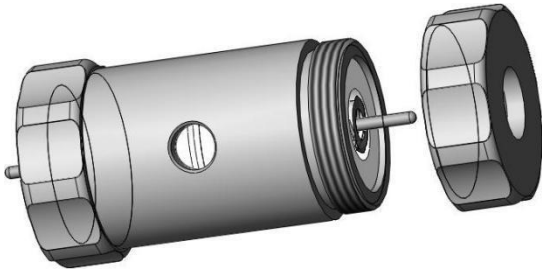

Connect another container nut (1) to the housing (2), and tighten two container nuts (1) on the housing (2) firmly.

Step 6

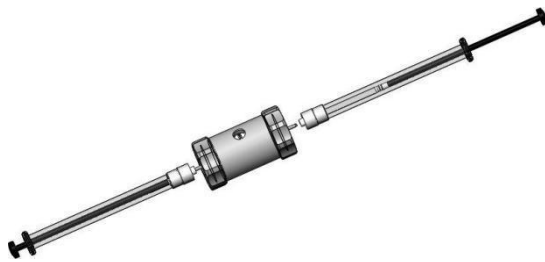

For HandExtruder-1mL

Connect the gas-right syringes to the container nuts, one syringe is filled with samples as a feeding syringe, another is empty as a receiving end.

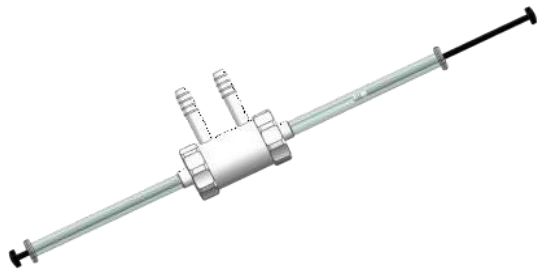

For HandExtruder-1mL-RT

Step 7

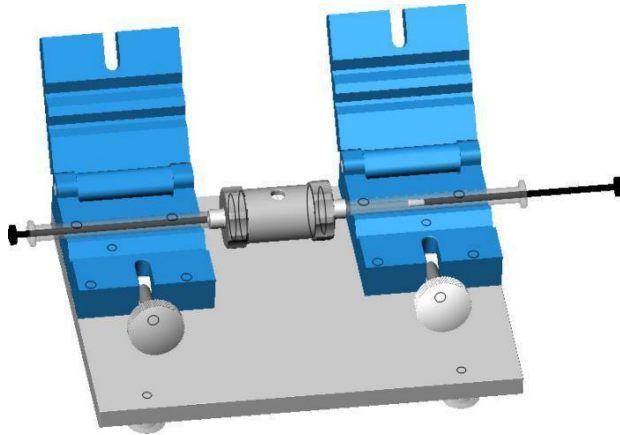

For HandExtruder-1mL

Place the components assembled in step 6 to the stabilizer (5), and the manhole cover should be suppressed with bolt cap. Please pay attention to the tightness of the bolt as the syringe is made of glass.

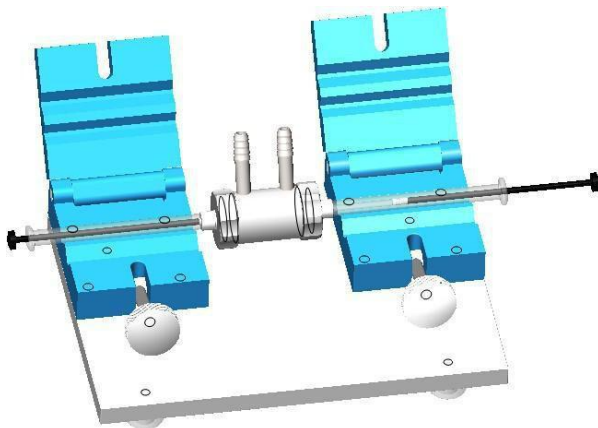

For HandExtruder-1mL-RT

There are two specifications of grooves on the stabilizer (5), the small groove is suitable for 0.5 mL syringe while the large groove is suitable for 1.0 mL syringe.

Step 8

The completed installation is shown below.

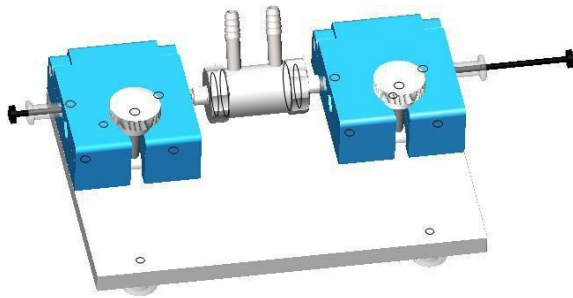

For HandExtruder-1mL-RT

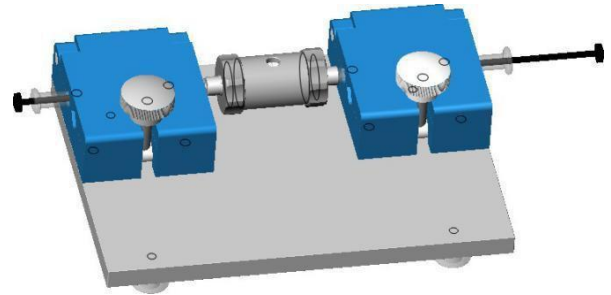

For HandExtruder-1mL

6. General Operating Steps

6.1 Operation Steps

As shown in step 8, after the equipment installation, push the piston of gas-tight syringe that filled with materials to start work, on the other hand, the empty syringe on the other side shall be used as materials collector; moreover, when this action is completed, push the piston of collector syringe to re-start operation. Repeat the actions until the size of materials reaches to requirement.

Note: As the syringe cylinder is made of glass, the operation

needs to be careful.

6.2. General Cleaning Procedure

It applies to the general cleaning of extruder; certain compounds may require specific cleaning procedures.

1. The extruder should be washed out immediately after use, please disassemble its parts according to **4. Parts list**.
2. It is suggested to use phosphate-free detergent, water temperature should be moderate; Additionally, a brush can be used in places that are difficult to clean, wash with plenty of tap water after warm soapy water.
3. Wash with distilled water for several times after tap water cleaning.
4. All stainless steel parts should be washed with 70% ethanol, except O-rings, as O-ring may be corroded in 70% of the organic solvent.

7. Trouble Shootings

7.1 When the extruder is leaking, please disassemble for inspecting if all O-rings are in good condition and installed correctly. Also, check if the fasteners are loose.

7.2 The following factors are likely to cause slow filtration:

721 It could be the possibility that the inappropriate-size liposome membrane that being used. Filtrating large particle materials through nano-pore membrane with too small pore size, the process can be very slow, it is recommended to use nano-pore membrane with larger pore for filtration, and then use a small one to continue.

722 It could be the possibility that some temperature-sensitive material is coagulated at the operating temperature, resulting in large filter resistance, so it is recommend of adjusting the operating temperature.

723 Nano membrane has been blocked; making the filtration capacity reduced greatly, replacement is advised.

724 It may be caused by uneven distribution of the material mixture, please improve the pretreatment.



Instruction Manual

High-pressure Jacketed Extruder

Genizer Liposome Extruder System

Solution for liposome and nanoparticle extrusion

	Catalog No.	Thermo-control	Power mode		Micron-pore plate	Maximum pressure	Dimension L×W×H(cm)/Weight(kg)	Nano membrane
			Air	Online				
Test Scale	HandExtruder-1ml-RT	Optional	/	/	/	700 psi	23×17×33/2 (jacketed)	30 nm
	HandExtruder-1ml						23×17×13/2	
	GExtruder-10ml	Optional	Y	Y	Y	3,000 psi	23×13×25/4 (jacketed)	
	GExtruder-5ml/min						10×10×8/1	
Pilot Scale	GExtruder-100ml	Optional	Y	Y	Y	3,000 psi	23×20×32/7 (jacketed)	50 nm
	GExtruder-50ml/min						12.5×12.5×9/2	80 nm
	GExtruder-800ml	Optional	Y	Y	Y	3,000 psi	25×25×37/20 (jacketed)	100 nm
	GExtruder-400ml/min						18×18×10/5	
Production Scale	GExtruder-3000ml	Optional	Y	Y	Y	3,000 psi	30×25×55/45 (jacketed)	200 nm
	GExtruder-1500ml/min						30×25×25/21	
Production Scale	GExtruder-10000ml	Optional	Y	Y	Y	3,000 psi	45×40×65/130 (jacketed)	400 nm
	GExtruder-5000ml/min						45×40×30/90	
Customize Scale	GExtruder 0-50000ml or Multi-Extruder	Optional	Y	Y	Y	up to 6,000 psi	TBD (jacketed) TBD	800 nm

Notice: The dimension, structure and parameter should be subject to the final product.